

AXIOHM PRESENTS A NEW TURNKEY THERMAL PRINTING SOLUTION: TPSK Kiosk

60 mm

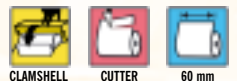

DRESSER WAYNE IS A LEADER IN THE PETROLEUM DISPENSER MARKET IN THE USA.

WAYNE IS THE INVENTOR OF THE "COMPUTER" PUMP, WHICH NOT ONLY TRACKS THE AMOUNT OF FUEL DISPENSED, BUT ALSO CALCULATES ITS PRICE TO THE CUSTOMER.

WAYNE HAS CHOSEN THE AXIOHM TPSK KIOSK FOR ITS "VISTA" GAS PUMP SERIES, AND WILL INTEGRATE IT ON ITS NEW DISPENSER GENERATION AS WELL: THE "OVATION".

WAYNE selected the AXIOHM TPSK kiosk as THE BEST SOLUTION for its gas dispensers because of :

- the successful experience it already had with AXIOHM's thermal mechanisms for many years,
- the patented manual cutter with integrated paper chute that insures easy and safe paper receipt handling,
- the famous AXIOHM CLAMSHELL™ system which makes paper roll changing a snap.
- customized design.

The TPSK kiosk in a few words:

- Paper width: 60 mm
- Printing width: 48 mm
- Printing speed: up to 100 mm/s
- Text, logos and barcodes
- A wide range of drivers available
- Paper out, paper low and door open sensors

THE TPSK KIOSK CAN BE THE PRINTING SOLUTION ANSWER IN A VARIETY OF APPLICATIONS: CAR WASH SYSTEMS, INTERNET TERMINALS, VENDING MACHINES, ETC...

TPSK KIOSK

60 mm



Axiohm

AN ORIGINAL CONCEPT: The integrated paper chute:

The paper is fed into a chute, the user has access to the ticket at the chute exit. The receipt is then cut by the user by pulling on the ticket end.

The chute hides the ticket from the user until it is fully printed. Our unique presenter, sensors, and software work together to avoid paper jams if the ticket is pulled during printing.

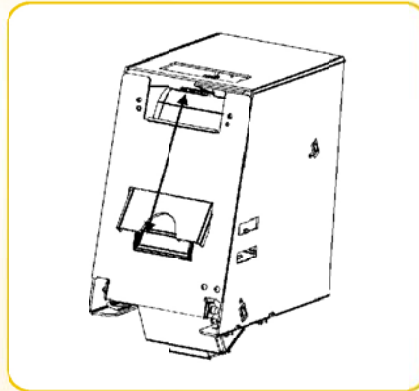

OTHER AXIOHM PRODUCTS:

Axiohm supplies a large family of thermal printers and accessories (cutters, cables, power supply,...), which offer customers a wide range of applications such as graphics, barcodes and receipt or label printing. Furthermore, an extensive range of OEM thermal mechanisms and turnkey printing solutions (kiosk printers) gives a maximum flexibility in design.

Our sales force is available to provide you with full support wherever you are. You can also rely on our Technical Support team, which will promptly respond to any technical inquiry and help you to integrate the thermal printing solution with your system.

TECHNICAL SPECIFICATIONS

CHARACTERISTICS	UNIT	REF: TPSK2400
Printing speed	mm/s	100
Printing width	mm	48
Resolution	dot/mm	8
Number of dots	dot	384
Columns	Column	24
Character size	dot*dot	16*24
Character type	-	Windows
Bar code type	-	Interleaved 2/5, EAN 8 & EAN 13, codabar, code 39 & code 128
Paper width	mm	60
Paper roll diameter	mm	102
Paper thickness	g/m ²	60
Paper loading	-	Clamshell™
Voltage	V	24
Current consumption	A	2.5 (average) - 13 (peak)
Head pulse life	pulse	1*10 ⁸
Mechanical reliability	km	50
Dimensions (W*D*H)	mm	102*160*204
Weight	g	1700
Operating temperature	°C	-10 to 50
Operating humidity	%RH	20 to 85
Cutter	-	Yes (automatic by pulling the ticket)
Cutter life	cut	300 k
Presenter	-	Paper chute integrated
Data buffer	kB	2
Interface	-	RS 232 (HE10 10 pin connector)
Driver	-	Windows 98/Me/00/XP
Safety standards	-	UL, CSA, FCC Class A, CE
Sensors	-	Paper out, paper low & door open
Options	-	power supply, communication cable

 NW printtech inc.

3700 Illinois Lane
Bellingham, WA 98226

Phone (360) 933-1040
Fax (360) 933-1034
Toll Free 1-866-922-1003

© 2003 AXIOHM. All rights reserved Worldwide. Patents pending.
All trademarks or registered trademarks are the property of their
respective owners. Printed in France.
Product specifications are subjected to change in order for AXIOHM
to continue to meet the needs of the market.

www.nwprintech.com

Distributed by :